



RPS-401A, RPS-426A

Features

- Adjustable Zero & Span
- Analog Current & Voltage Outputs
- Various Sensing Ranges
- Selectable Inverted & Non-Inverted Outputs
- Narrow Sensing Beam
- Self Contained Barrel Housing
- LED Strength Indicator
- Input Voltage 20 - 30VDC
- Short Circuit Protected
- RPS-401A in Plastic Housing
- Reverse Polarity Protected
- RPS-426A in Stainless Steel Housing



The RPS-401A, RPS-426A analog ultrasonic sensor is mounted in a barrel housing and is completely self contained. It is powered by 20-30VDC and is reverse polarity protected. It also has a narrow beam angle which enables it to get into tight places. A flat target can tilt up to 8 degrees and still be detected. The RPS-401A, 426A has 2 short circuit protected analog outputs, 4-20mA and 0-10 VDC. These outputs can easily be inverted and can be scaled over almost any range by means of adjusting the zero (P1) & span control (P2). For set-up purposes an LED strength indicator is provided. This LED is Green when not detecting and fades to Red as a target moves into place, depending on how much reflected signal is coming from

the target. The frequency of operation for the RPS-401A is 212kHz for the 4" to 40" and 150kHz for the 8" to 80". The RPS-426A has a 8" to 80" range and operates at a frequency of 150kHz. The RPS-401A barrel is constructed of plastic valox, and the RPS-426A is Stainless Steel. The barrel measures 30mm x 100mm. A standard 6' cable is provided. An optional quick disconnect plug is available.

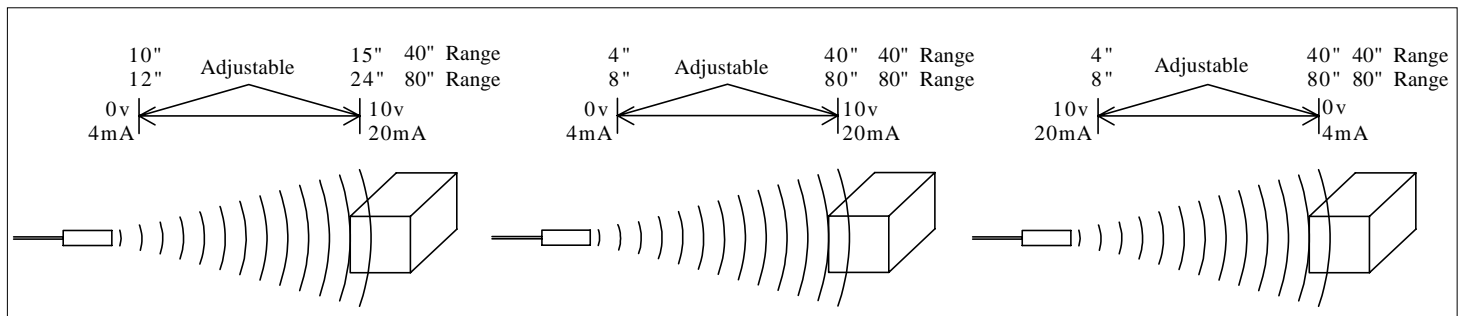

Minimum Analog Ranging

Analog sensing in the Minimum sensing configuration means detecting an object over a 5" range with the RPS-401A-40. This 5" span can be adjusted to occur over any part of the sensors range. For example it could be adjusted to occur from 10" to 15" or 25" to 30". This is done by means of the two potentiometers on the sensor. This sensor has a 5 : 1 adjustment ratio on its analog output, meaning that the RPS-401A-40 has a maximum span of 36" (range 4" to 40"). The analog output can also be adjusted anywhere between the 5" and 36" spans. These adjustments are made by the two potentiometers on the sensor. With no more than two adjustments of each potentiometer the desired range will be achieved.

Maximum Analog Ranging

Analog sensing in the Maximum ranging configuration means detecting an object over a 36" range with the RPS-401A-40. This 36" span goes from the sensors minimum sensing distance (4") to its maximum sensing distance (40"). The adjustment procedure is the same as described in the minimum analog ranging section. The RPS-401A-80 and RPS-426A-80 in the maximum ranging configuration detect an object over a 72" range. This span goes from the sensors minimum sensing distance of 8" to its maximum sensing distance of 80". This sensor also has a 5 : 1 adjustment ratio on its analog output so its minimum analog ranging capability is a span of 12". These adjustments are made by the two potentiometers on the sensor.

Inverted Analog Outputs

The RPS-401A has the ability to invert its analog outputs, meaning that the current or voltage will decrease with distance. For the current output to be inverted the voltage output needs to be tied to the positive of the supply voltage of the sensor. This then will invert the current output to 20mA - 4mA. To make the voltage output inverted 10v - 0v the current output needs to be tied to the positive of the supply voltage. In the standard mode of operation (non-inverted) P1 adjusts the near point 4mA (0v) and P2 adjusts the far point 20mA (10v). In the non-standard mode of operation (inverted) P1 adjusts the near point 20mA (10v) and P2 adjusts the far point 4mA (0v).

Specifications:

Operational Range:	Adjustable 4" to 40"	
RPS-401A	Adjustable 8" to 80"	
RPS-426A	Adjustable 8" to 80"	
Power Input:	20 - 30VDC Reverse Polarity Protected	
Input Current:	50 Milliamps	
Ambient Temperature:	0°C to 60°C or 32°F to 140°F	
Humidity:	0% - 95% Non-Condensing	
RPS-401A Housing:	420D valox plastic with a silicone rubber sensing face.	
RPS-426A Housing:	303 Grade Stainless Steel with a 316 Grade Stainless Steel sensing face.	
Outputs:	Current Sourcing Analog Output 4 - 20mA Inverted & Non-Inverted Analog Voltage Output 0 - 10 volts Inverted & Non-Inverted Short Circuit Protected	
Transducer Frequency:	4" to 40" RPS-401A : 212kHz	8" to 80" RPS-401A : 150kHz RPS-426 : 150kHz
Response Time:	4" to 40" 16mS	8" to 80" 35mS
Weight:	11 ounces	

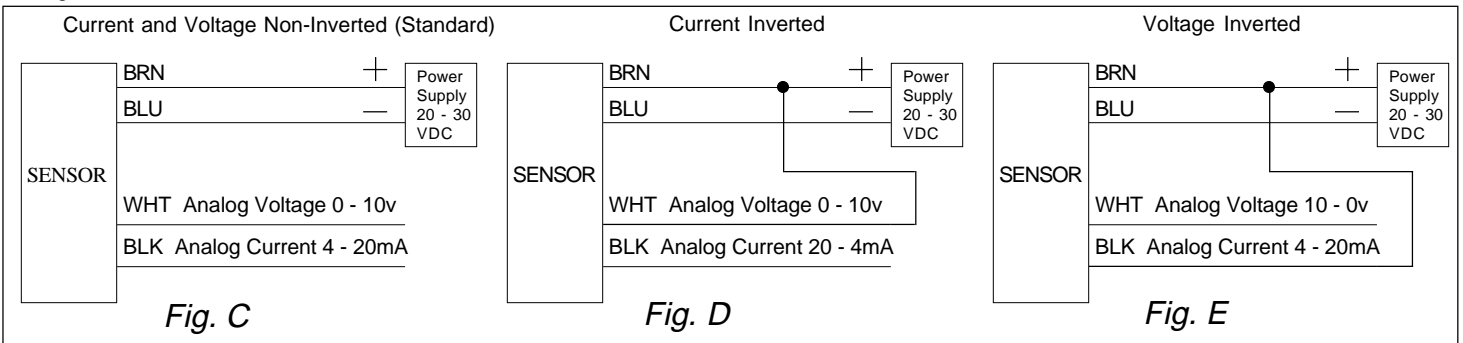
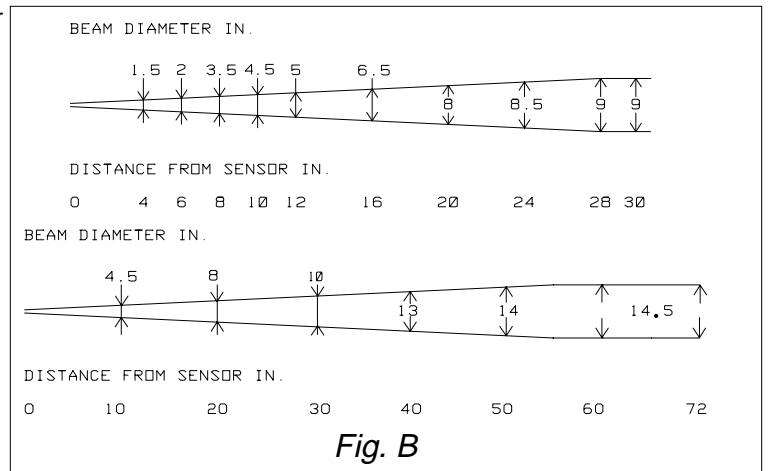
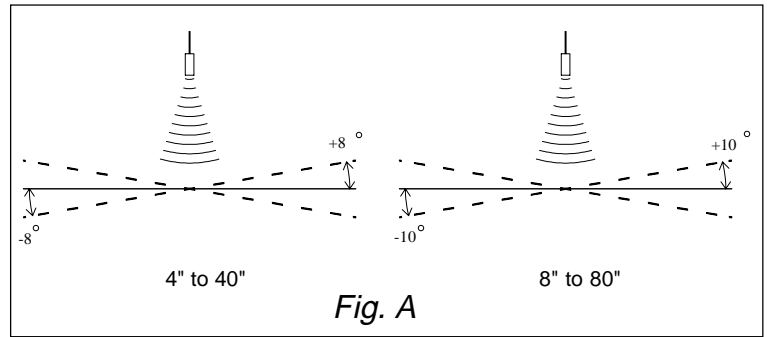
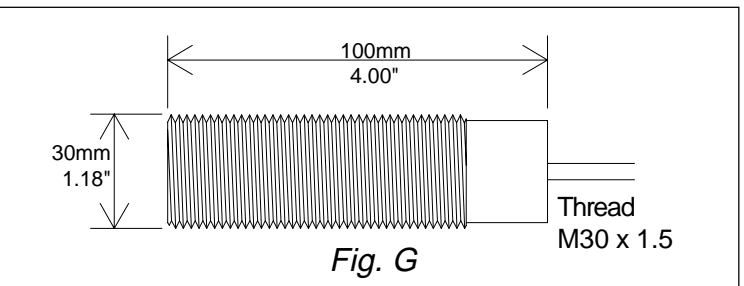
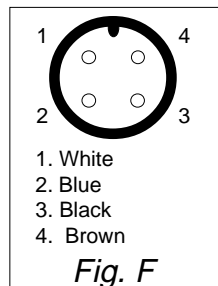

Figure:

- A - Angle of Tilt
 - B - Beam Spread
 - C - Wiring Diag. RPS-401A Standard
 - D - Wiring Diag. RPS-401A Current Inverted
 - E - Wiring Diag. RPS-401A Voltage Inverted
 - F - Connector Diag. "QD" option (Male View)
 - G - Mounting Dimensions
- NOTE: See page 51 for additional information on "QD" cable.
"QD" cables are sold separately.



PART NUMBER	RANGE	OUTPUT
RPS-401A-40	4" to 40"	0 - 10VDC and 4 - 20mA Analog
RPS-401A-80	8" to 80"	0 - 10VDC and 4 - 20mA Analog
RPS-401A-40QD	4" to 40"	0 - 10VDC and 4 - 20mA Analog - Quick Disconnect
RPS-401A-80QD	8" to 80"	0 - 10VDC and 4 - 20mA Analog - Quick Disconnect
RPS-426A-80	8" to 80"	0 - 10VDC and 4 - 20mA Analog
RPS-426A-80QD	8" to 80"	0 - 10VDC and 4 - 20mA Analog - Quick Disconnect
5000118-3		6' Cable for "QD" option
5000118-6		16' Cable for "QD" option



(815) 338-5800 / FAX: (815) 338-5803

935 Dieckman Rd., Woodstock, IL 60098 USA
<http://www.migatron.com> e-mail: info@migatron.com